



iSED[®]

**Automated Erythrocyte Sedimentation Rate
Analyzer**

OPERATOR'S MANUAL

This page intentionally blank.

Dear *iSED*® Customer,

ALCOR Scientific would like to welcome you into the world of fast, efficient and accurate erythrocyte sedimentation rate (ESR) results. With our welcome, we have provided you a packet of information to get you started. We hope this information will make using the *iSED* even easier. Please find enclosed:

***iSED* Quick Reference Guide**

This Quick Reference Guide includes simple setup and operating instructions.

Warranty Card

The instrument is backed by a One (1) Year Warranty. In order to assure coverage, you must activate your Warranty by filling out the warranty card included with your instrument, and mailing it back to ALCOR. The serial number label is located on the rear panel of the analyzer. Please see the last page of the Operator Manual for more information and instructions.

ALCOR Scientific offers Technical Support Monday through Friday 8:30am-5:00pm EST (excluding all US Federal Holidays) to help service you in the quickest way possible. The Technical Support Team can be reached by any of the following:

Toll Free: (800) 495.5270 (USA Only)
+1 (401) 737.3774

Fax: +1 (401) 737.4519

Mail: ALCOR Scientific
20 Thurber Blvd
Smithfield, RI 02917 USA

Email: techservice@alcorscientific.com

Please do not hesitate to contact ALCOR or your authorized ALCOR distributor if you have any questions regarding any of the information found in this manual.

















We thank you for selecting ALCOR products and look forward to serving your laboratory!

Best Regards,

ALCOR Scientific Support Team

Symbols Reference

The following is a list of symbols and their meaning used on the instrument, consumables and accessory labeling.

Symbol	Meaning
	Instrument satisfies requirements of European directive on in vitro diagnostic medical devices (98/79/EC)
	Date of manufacture
	Manufacturer
	Serial Number
	In Vitro Diagnostic Medical Device
	Product/Reference number
	Fuse Rating (located on serial number label, replace with same value and type)
	AC Single Phase Alternating Current
	Consult instructions- refer operator to the instruction manual for additional information
	Temperature limitation –Indicates storage requirements range
	WEEE: Disposal of Waste Electrical and Electronic Equipment
	Biological Hazard: Universal precautions should be followed
	Caution: Moving Parts
	Caution: Sharp Needle
	Warning: Consult operator manual and observe safety warnings
	Caution: May Cause Electrical Shock
	Caution: Object is heavy. Use care and/or assistance in lifting

1.	Intended Use	7
2.	Methodology	7
2.1.	History.....	7
2.2.	Comparison with Existing Methods.....	8
2.3.	Method Limitations.....	8
3.	Principle of Procedure	8
4.	General Information	9
4.1.	<u>For In Vitro Diagnostic Use Only</u>	9
4.2.	Notes, Precautions, Warnings and Biological Warnings.....	9
4.3.	Precautions and Safety Information.....	10
4.4.	Sample Requirements.....	11
4.5.	Tube Requirements.....	11
5.	Instrument Overview	12
5.1.	Features.....	12
5.2.	Parts Identification.....	12
5.3.	Consumables.....	13
5.4.	iWASH Fluid.....	13
6.	Unpacking and Installation	14
6.1.	Unpacking the Instrument.....	14
6.2.	Contents of the Box.....	15
6.3.	Power Connection.....	16
6.4.	RS-232 connection.....	16
7.	Start-Up	18
7.1.	Icon Legend.....	18
7.2.	Touch Screen Menus.....	19
7.3.	Programming Date and Time.....	20
8.	Operating Instructions	21
8.1.	Patient Identification.....	21
8.2.	Auto ID Procedure.....	22
8.3.	Manual Data Entry for Barcoded Tube.....	23
8.4.	Manual Patient Data Entry for Non-Barcoded Tubes.....	24
8.5.	Format of Automatically Assigned Identification.....	24
9.	Sample Collection	25
9.1.	Compatibility with CBC Collection Tubes.....	25
9.2.	Collection Procedure (conducted by trained personnel only).....	25
10.	Calibration	26
11.	Limitations of Procedure	26
12.	Results	27
12.1.	Expected Values.....	27
12.2.	Results Format.....	27
12.3.	Printed Results with Error Message.....	29
12.4.	Reprinting of Results (Entire day).....	29
12.5.	Review/Printing/Retransmitting a Single Result.....	29
13.	Performance	30

14. Smart Cards	30
14.1. Downloading Credits from Test Card	31
14.2. Low and Zero Credit Indicators and Alarms	31
15. Routine Maintenance	33
15.1. Replacing Printer Paper	33
15.2. Replacing/Emptying the Waste Bottle	34
15.3. Waste Bottle Full Indicators and Alarms	35
15.4. Replacing iWASH Bottle	37
15.5. iWASH Bottle Empty Indicators and Alarms	38
15.6. Replacing the Fuse	40
16. System Status, Error Codes and Warning Messages	41
16.1. System Status Messages	41
16.2. System Warning Messages	42
16.3. System Error Messages	43
16.4. Sampling Error Messages	44
16.5. Print Out of Sampling Error Message	45
17. Troubleshooting	46
18. Safety Precautions	47
18.1. General Considerations	47
18.2. Biological Waste	47
19. Preventative Maintenance	48
19.1. Deep Clean Procedure	48
19.2. Pump Tubing Change Required Message	49
19.3. 30,000 Test Aspirations Message	49
19.4. General Considerations	50
19.5. Spare Parts	50
20. Technical Support	51
21. Technical Specifications	52
22. Quick Reference	53
23. Warranty Information	54

1. Intended Use

The iSED Erythrocyte Sedimentation Rate analyzer, is an automated sedimentation rate analyzer which reports sedimentation rate in mm/hr. It is a non-specific, quantitative result. Testing is done using EDTA/whole blood samples, obtained by venipuncture or capillary blood collection. The instrument can be used in laboratories authorized to perform test classified as Moderately Complex under CLIA categorization by order of a physician to aid in assessing the general health status of a patient.

2. Methodology

2.1. History

The discoverer of ESR in 1897 was a Polish physician, Edmund Faustyn Biernacki ¹ (1866–1911). The most important conclusions from his observations were as follows: the blood sedimentation rate is different in different individuals; blood with small amounts of blood cells sediments faster; blood sedimentation rate depends on the level of plasma fibrinogen; in febrile diseases (rheumatic fever included) with high levels of plasma fibrinogen the ESR is increased; and in defibrinated blood the sedimentation process is slower. The findings presented by Biernacki clearly showed the clinical significance of ESR.

In 1921, Swedish internist Alf Vilhelm Albertsson Westergren (1891–1968), presented a similar description of the phenomenon of ESR ² as those given by Biernacki and Swedish hematologist, Robert Sanno Fåhræus (1888–1968) ³. Westergren applied a blood sampling method to the ESR test using sodium citrate as anticoagulant. Westergren also defined standards for the ESR test and to which nearly all other automated ESR analyzers are referenced today. ^{4, 5}

The *iSED* uses advanced Rheology Technology to measure the “earliest and most critical phase” of the Erythrocyte Sedimentation, which is called Rouleaux Formation. It is well known, in fact, that the rouleaux formation is the critical phase of ESR and the one that it is ultimately determine the length at which the red cells will sediment in the Westergren tube.

In essence, the technical innovation of the *iSED* consists of “**directly**” measuring the aggregation of the red blood cells, while the traditional ESR measure “**indirectly**” the aggregation of the red blood cells by recording the length at which the red cells settle in a Westergren tube.

After measuring the aggregation directly, the *iSED* produces ESR results in mm/hr. Utilizing EDTA blood from the primary tube, results are reported within seconds.

¹ Biernacki E. Die spontane Blutsedimentirung als eine wissenschaftliche praktisch-klinische untersuchungsmethode. Dtsch Med Wschr 1897; 23: 769–72.

² Westergren A. Studies of the suspension stability of the blood in pulmonary tuberculosis. Acta Med Scand 1921; 54: 247–82

³ Fåhræus R. Über die Ursachen der verminderten Suspensionsstabilität der Blutkörperchen während der Schwangerschaft. Biochem Z 1918;89:355–64

⁴ International Council for Standardization in Haematology (Expert Panel on Blood Rheology): ICSH recommendations for measurement of erythrocyte sedimentation rate. J Clin Pathol 1993; 46:198-208

⁵ Thomas RD, Westengard JC, Hay KL, et al: Calibration and validation for erythrocyte sedimentation tests. Arch Pathol Lab Med 1993; 117:719-72.

2.2. Comparison with Existing Methods

Current ESR testing methods include manual, standing capillary tube type devices and automated systems utilizing proprietary blood collection vials. These methods typically have test times of 20 to 60 minutes, may require open container blood transfer and minimum blood volumes of greater than 1ml, which may result in extra blood drawing.

The iSED erythrocyte sedimentation rate analyzer is design to sample directly from the primary (lavender top) 13 x 75mm, EDTA blood collection tube, automatically withdraw a test sample of 100µL volume and can produce a result in as little as 20 seconds, with appropriate prior homogenization (ref. sec 13.2). The instrument's micro-flow cell allows capture of the critical kinetics of red blood cells aggregation in a highly controlled testing environment. This system eliminates handling and the associated factors that can contribute to result variability. The iSED reports results which have been correlated with the Westergren method.

2.3. Method Limitations⁶

The erythrocyte sedimentation rate is a transient phenomenon confined to fresh blood. It is not a hematic matrix component at the corpuscular or molecular level. The procedures used to determine the ESR cannot be calibrated since they are susceptible to a variety of factors, e.g. temperature, hematocrit, erythrocyte mean corpuscular volume, plasma viscosity, etc. For this reason, it is possible to observe instrument performance deviations, compared to other procedures, when the above variables are not taken into account. Erythrocyte sedimentation remains a confusing, partly understood phenomenon and, clinically, is a nonspecific reaction. It is highly recommended to perform other tests together with ESR since a normal ESR value is not enough to exclude that the patient is not affected by a pathology.

Sample mixing is performed at the beginning of the analysis with the purpose of homogenizing the sample. An inefficient homogenization can affect the results given by the instrument.

Interferences that may increase ESR values:

- Increased levels of Fibrinogen and gamma globulins.
- Technical factors such as mechanical vibrations and elevated room temperature.

Interferences that may decrease ESR values:

- Specimen quality such as blood to anticoagulation ratio, age of specimen and fill volume.
- Decreased room temperature.

3. Principle of Procedure⁷

The ESR is a simple non-specific screening test that indirectly measures the presence of inflammation in the body. It reflects the tendency of red blood cells to settle more rapidly in the face of some disease states, usually because of increases in plasma fibrinogen, immunoglobulins, and other acute-phase reaction proteins. Changes in red cell shape or numbers may also affect the ESR.

When anticoagulated whole blood is allowed to stand in a narrow vertical tube for a period of time, the RBCs – under the influence of gravity - settle out from the plasma. The rate at which they settle is measured as the number of millimeters of clear plasma present at the top of the column after one hour (mm/hr). The RBCs sediment because their density is greater than that of plasma; this is

⁶ CLSI. *Procedures for the Erythrocyte Sedimentation Rate Test; Approved Standard-Fifth Edition*. CLSI document H02-A5. Wayne, PA: Clinical and Laboratory Standards Institute; 2011.

⁷ McGill University, The McGill Physiology Virtual Laboratory, 200

particularly so, when there is an alteration in the distribution of charges on the surface of the RBC (which normally keeps them separate from each other) resulting in their coming together to form large aggregates known as rouleaux. Rouleaux formation is determined largely by increased levels of plasma fibrinogen and globulins, and so the ESR reflects mainly changes in the plasma proteins that accompany acute and chronic infections, some tumors and degenerative diseases. In such situations, the ESR values are much greater than 20mm/hr. Note that the ESR denotes merely the presence of tissue damage or disease, but not its severity; it may be used to follow the progress of the diseased state, or monitor the effectiveness of treatment.

4. General Information

Read this manual carefully prior to operating the instrument.

This document is the operator's manual for the instrument. It is intended to explain the instrument operation in detail and can be used as a basis for training new operators. It is an information guide and troubleshooting reference. Retain this manual for future use.

4.1. **For In Vitro Diagnostic Use Only**

4.2. Notes, Precautions, Warnings and Biological Warnings

The Operator's Manual includes information and warnings. These need to be observed by the operator in order to ensure safe operation of the instrument. There are four types of messages: Notes, Caution, Warnings and Biological Warnings.

Notes

NOTE: Highlights important facts, gives helpful information and tips and clarifies procedures.

Cautions



CAUTION: Electrical caution! Unplug before handling.



CAUTION: Important information on the proper operation of the instrument. This information is crucial in preventing instrument damage and maintain the system.

Warnings



WARNING: Identifies potentially hazardous situations that could result in serious injury to laboratory personnel.

Biological Warnings



WARNING: Universal precautions should be followed. Always wear gloves to prevent exposure to pathogens.

4.3. Precautions and Safety Information



Please pay close attention to the instructions, notes and symbols as well as the standard laboratory practices outlined by your facility and local regulatory agencies.



Always keep a distance of at least 4 inches (10 cm) between the rear of the instrument and the wall to allow for proper ventilation.



Do not use power frequencies or voltage other than those specified in this document. Connection to an inappropriate power source may cause injury or fire.



Do not disassemble or modify the instrument. Doing so may cause injury and /or instrument malfunction and void the warranty.



Place the instrument on a stable and level surface free of vibration. Failure to do so may cause injury or malfunction of the unit.



CAUTION: To reduce the risk of electrical shock, do not remove any panel unless under the direction of qualified personnel.



Do not block any ventilation openings.



Do not place instrument in water



Do not drop or throw the instrument



Operate the instrument on a dry, level surface



Do not move the instrument while specimens are processing



Plug the instrument into a grounded power source



Tubes must be tightly capped prior to loading them on to the iSED.



Do not operate iSED without sample collection tray.



Empty sample collection tray to prevent overflow of tubes.



WARNING: For continued protection against risk of fire and hazard, replace only with the same type and rating fuse.



WARNING: The instrument's main power switch is used as the main disconnect device.



WARNING: Observe Universal Precautions. Discard contaminated materials according to applicable regulations.

4.4. Sample Requirements

Sample volume for testing is 100 μ L whole blood (500 μ L dead volume)

Sample volume for pediatric testing is 100 μ L whole blood (400 μ L dead volume)

Sample must be whole blood collected in K₃-EDTA or K₂ EDTA anti-coagulant tube

Sample should not be clotted or hemolyzed (**DO NOT mix vigorously!**)

Sample should be tested within 4 hours from venipuncture or within 24 hours if refrigerated

Sample must be brought to room temperature for at least fifteen (15) minutes (if refrigerated)

NOTE: The instrument requires no additional or special sample preparation. As with all anti-coagulant collection tubes, the sample should be well mixed after collection to help avoid clotting or other aggregates that may alter ESR test results.

4.5. Tube Requirements



13 x 75mm tube with pierceable cap

EDTA anti-coagulant (lavender top)

BD Microtainer® MAP Microtube



WARNING: Do not use if the tube stopper is missing!
Use only tightly capped samples!

5. Instrument Overview

The rate at which red blood cells aggregate in whole blood has a direct effect on the resulting sedimentation rate. Sedimentation rate is therefore an indirect representation of the rate of aggregation. The iSED erythrocyte sedimentation analyzer uses photometrical rheology to directly measure the aggregation of red blood cells. Once the sample is automatically processed and in position, a sensitive optical detector in the iSED follows the progress of aggregation over time. This produces a signal that is a direct representation of the aggregation. The magnitude of time-dependent change is correlated to the Westergren method.

5.1. Features

100µL sample directly from closed primary EDTA tube (with or without barcode)

Minimum results time 20 seconds (with prior homogenization)

No disposables

Fully automated

Continuous Feed

5.2. Parts Identification

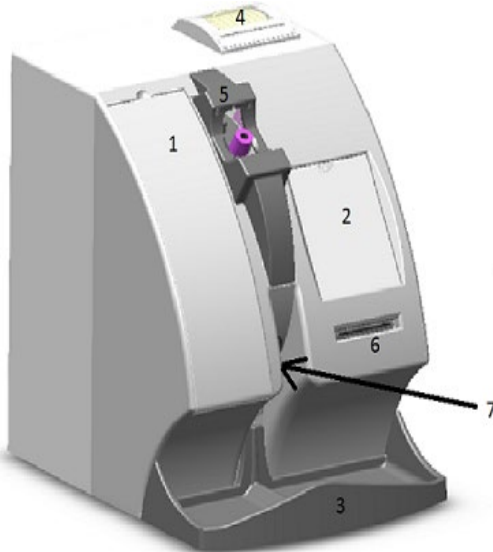

1	iWASH and Waste Compartment
2	Touch Screen
3	Sample Tube Return Tray
4	Printer
5	Sample Accessioning Port
6	Smart Card Reader
7	Sample Ejection Port

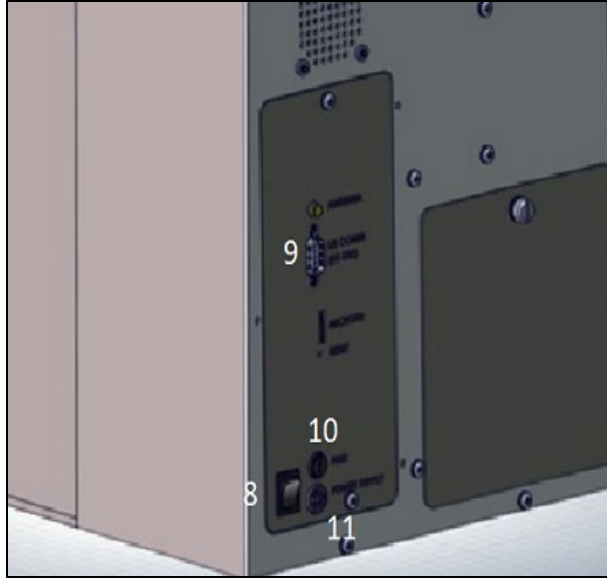

8	On/Off Switch
9	RS- 232 Connection Port
10	Fuse
11	Power Connection Port

5.3. Consumables

Item	Description	Reorder Part #
Printer Paper	57mm x 25mm (3 pack)	DS-05233
Test Card	Preloaded smart card for <i>iSED</i> , available with tests in various quantities	112-01000 (1,000 preloaded tests) 112-02000 (2,000 preloaded tests) 112-05000 (5,000 preloaded tests) 112-10000 (10,000 preloaded tests) 112-20000 (20,000 preloaded tests)
iWASH® Fluid	500 mL bottle with screw cap, pre-filled with instrument iWASH (4 pack)	112-12-001
iWASTE® Bottle	500 mL plastic waste bottle with screw cap, (24 pack)	112-12-002
	500 mL plastic waste bottle with screw cap, (4 pack)	112-12-005

NOTE: Only use consumables that are within their expiration date.

5.4. iWASH Fluid

The instrument uses iWASH Fluid as the cleansing agent during the wash cycle.

The use of any other product could affect the performance of the instrument and void the warranty.

5.4.1. Specification

Type 1 Ultra-Pure Water: exceeds Clinical Lab Reagent Water (CLRW) specifications.

5.4.2. Continuous Operation Mode

It is recommended that the instrument remain on at all times and ready for use.

Should the instrument need to be powered off for any reason, run a wash cycle prior powering off the unit.

NOTE: The instrument is programmed to perform self-cleaning after being idle for fifteen (15) minutes following the last sample tested. The process takes approximately one (1) minute and utilizes approximately 4.5mL of iWASH for each wash cycle. Once completed, testing can resume as normal.

6. Unpacking and Installation



CAUTION: The instrument unit weighs 30 lbs. Use safe lifting techniques and proper techniques when handling heavy objects. If necessary, obtain assistance to safely lift the instrument.



CAUTION: If using a utility knife, extend the blade to appropriate length to avoid cutting any internal components.

All original packaging should be kept in the event the instrument needs to be returned for service or warranty repair. For more information, please refer to the Warranty Information in the Operator's Manual or call Customer Service at +1 401.737.3774.

6.1. Unpacking the Instrument

Inspect the shipping container for any obvious signs of mishandling or shipping damage. If damage is found, retain all package materials and immediately file a claim with the shipping carrier.

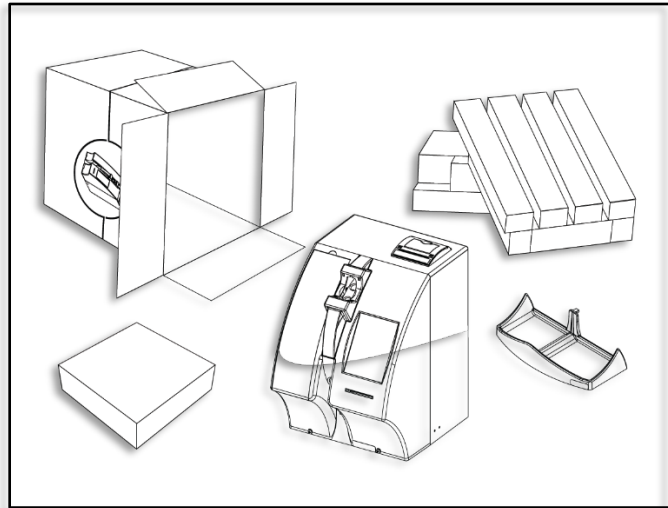
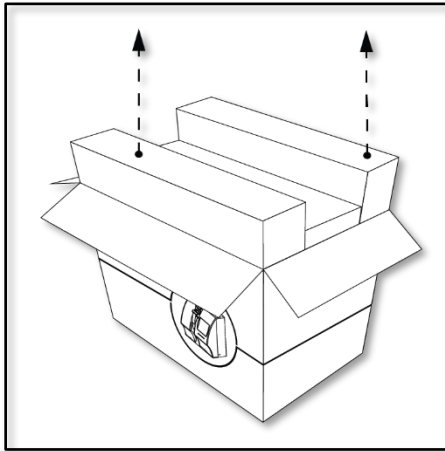
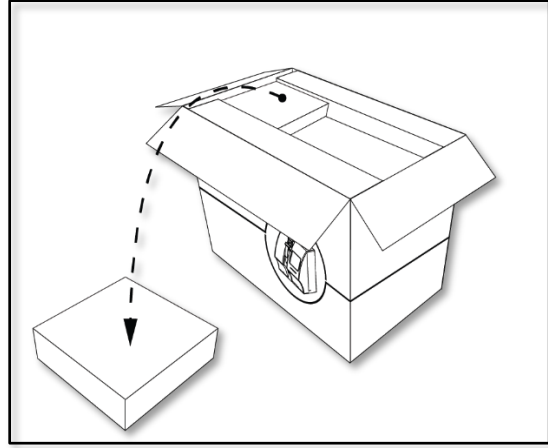
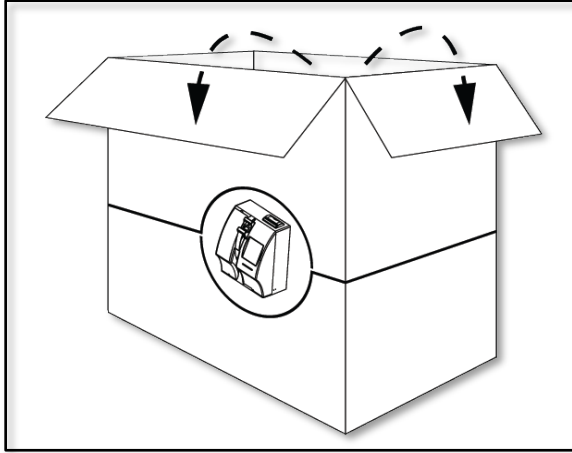

1. Position the box upright and open the top flaps
2. Remove the Accessory Box and set aside
3. Keep the box upright. Slowly slide the instrument and surrounding foam out of the box
4. Remove the Tube Return Tray and set aside
5. Remove the foam panels from the sides of the instrument
6. Place the instrument on a secure, flat surface and remove the instrument from the protective bag. **Save the box and foam pieces for future use!**

6.2. Contents of the Box

1. *iSED* instrument (1)
2. Power Cord and Power Adapter (1 each)
3. Sample Collection Tray (1)
4. Pre-filled *iWASH* Bottle (1)
5. Waste Bottle (1)
6. Thermal Paper (1)

7. Spare Fuse (1)
8. Operator's Manual with Warranty Information (1)
9. Product Registration Information card
10. Cables for future software upgrades
11. Micro-SD card adapter.

6.3. Power Connection

1. Connect the power cord to the power adapter
2. Insert the power adapter cord (with positive-lock connector) into the power connection port located on the rear panel of the instrument.

Note: Please ensure that the flat side of the plug faces the power switch when connecting to receptacle on iSED.



3. Place the instrument in its permanent operating location and plug the power cord into a standard wall outlet.
4. To power the unit on, press the On/Off switch located on the rear of the instrument



CAUTION: Always keep a distance of at least four (4) inches (10 cm) between the rear of the instrument and the wall to allow for proper ventilation.



CAUTION: Place the instrument on a stable and level surface free of vibration. Failure to do so may cause injury or malfunction of the unit.



CAUTION: Operate the instrument on a dry, level surface.

6.4. RS-232 connection

The analyzer is equipped with an RS232 DB9 male connector for data transfer. The pin-out of the connector is described in the following drawing.

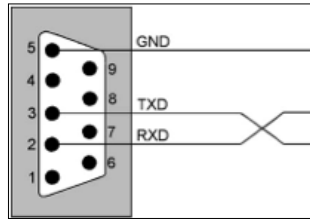

























For more information, **Document 112-09-020 Communication Protocol** is available upon request.

7. Start-Up

7.1. Icon Legend

All instrument functions can be accessed by using the touch screen. The following chart identifies all icons and their function when pressed:

	Add Sample		Select
	End/Stop		Return
	Retrieve Stored data		Print
	Service		Show Next Sample
	Send to LIS		Show Previous Sample
	Adjust Time/Date		Home (Measure Screen)
	Add Sample (Manual Patient Data Entry)		Backspace
	Deep Wash Cycle. This will require a 13x75 tube filled with 6-8 % Bleach. Follow instructions on screen.		Wash Cycle. This icon replaces: 
	Replace iWASH Bottle (Reset Wash Counter)		Replace Waste Bottle (Reset Waste Counter)
   	Displays current approximate volume of iWASH and Waste Bottles. A Green Bar is displayed as a volume indicator.		

NOTE: For iSED software versions before 3.01A, both wash cycle icons will instead be represented by a single  icon.

7.2. Touch Screen Menus

The instrument is touch screen and all programming can be done by selecting or inputting data on the following screens:

Home Screen:

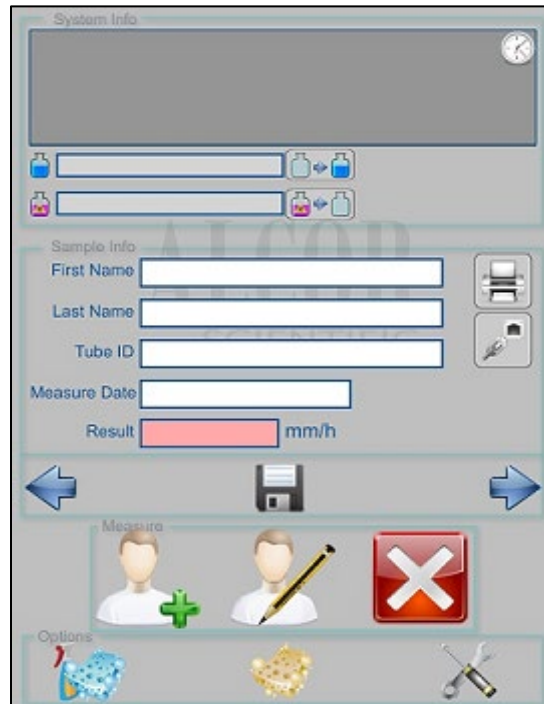



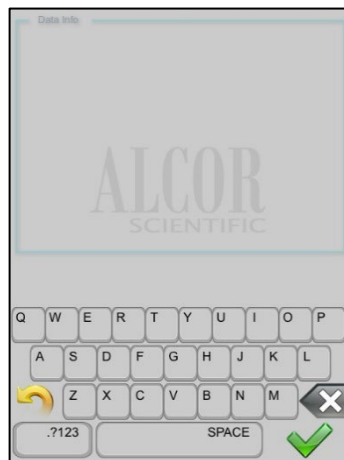



Alpha and Numeric Key Boards:



7.3. Programming Date and Time

To program the date and time on the instrument, the below procedure should be followed:

1. From the main screen, touch the  icon located in the top right corner of the System Info frame
2. Keyboard will appear prompting the operator to input Month data using the numerical equivalent, once entered, touch the  icon to proceed
3. Enter the Day information and touch the  icon to proceed
4. Enter Year information and touch  icon to proceed
5. Enter Hour information and touch the  icon to proceed
6. Enter Minute information and touch  icon to proceed
7. Touch the  icon to proceed

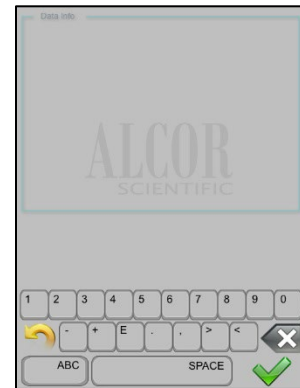

8. Operating Instructions

NOTE: Always run a wash cycle prior to switching power OFF.

8.1. Patient Identification

Barcoded Tubes: Patient samples are read and identified by the instrument's internal barcode reader automatically as they are loaded into the instrument. All common laboratory barcodes are supported, including Code 39, UPC and Code 93 formats. Note barcode location range:

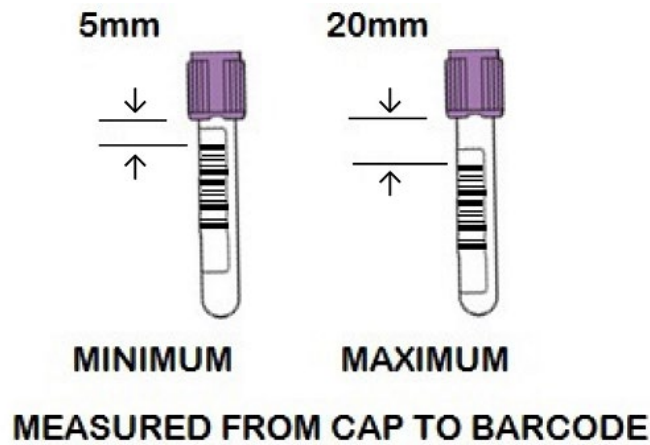

For instances when patient identification cannot be read by the internal barcode reader or there is no barcode present the operator may enter data manually. **For instructions on manually entering patient data, please refer to Section 8.4.**

8.2. Auto ID Procedure

All sample mixing, sample extraction, sample reading and sample disposal are handled automatically by the instrument. Up to 20 sample tubes may be loaded into the sample wheel at any given time. As each sample is processed (20 seconds), the sample tube is ejected from the sample wheel and retained in the external sample collection tray. As soon as a sample is ejected, another tube may be placed in the sample wheel.

1. Touch the  icon
2. The sample wheel rotates to position the next open slot in the sample entry port

The onscreen information bar will report “waiting sample” and the instrument will beep quietly for five (5) seconds. As the five (5) second window draws to a close, beeping will become faster.

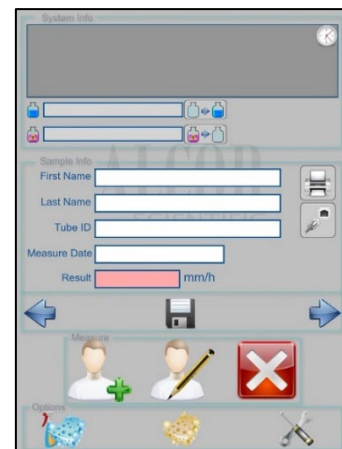

3. Insert the barcoded tube with the barcode oriented to the right. A red light will illuminate and a distinctive beep will sound when the barcode is successfully recognized
4. Automatic sample processing then begins
5. Repeat Steps 2-4 until all samples have been loaded and/or all positions in the sample wheel are occupied



NOTE: If the five (5) second window is missed, simply select the  icon again to restart the sample scheduling process.

8.3. Manual Data Entry for Barcoded Tube

The following procedure should be followed by the operator if the internal barcode reader is unable to read the barcode information on the inserted tube.

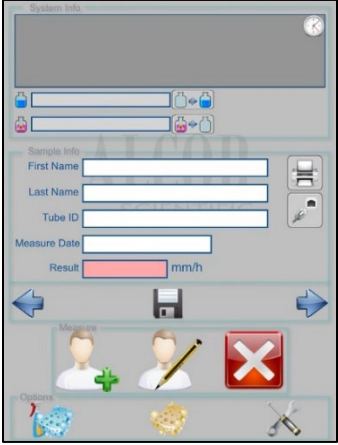

1. Touch the  icon
2. The sample wheel rotates to position the next open slot in the sample entry port
3. Insert the tube, the instrument will try and read the barcode, if unable the operator will be prompted to enter patient identification data manually using the alphanumeric keyboard
4. Remove tube from sample wheel to allow for a visual tube identification to input patient data (*Optional*)
5. Patient information must be recorded in one (1) or more of the following data fields:
 - Alphanumeric ID
 - Patient's First Name
 - Patient's Surname
6. Touch the  icon to skip a data field or to confirm entered information
7. Sample processing will begin once patient data has been entered



NOTE: (*For tubes removed from sample wheel*) If patient information data is not entered within ten (10) seconds from the last pressed key, the loading process will abort and the operator will restart the loading process for that tube.

NOTE: (*For tubes not removed from the sample wheel*) If patient information is not entered within ten (10) seconds from the last pressed key, the instrument will automatically assign an identification number. **See Section 8.5 for information on the format for identification number(s) automatically assigned by the instrument.**

8.4. Manual Patient Data Entry for Non-Barcoded Tubes

1. Touch the  icon as the sample wheel is rotating (indicated by instrument beeping) to position the next open slot in the sample entry port.
2. The instrument will prompt the operator to enter patient identification data manually using the alphanumeric keyboard. Patient information must be recorded in one (1) or more of the following data fields:
 - Alphanumerical ID
 - Patient's First Name
 - Patient's Surname
1. Touch the  icon to skip a data field or to confirm entered information
2. The sample wheel rotates to position the next open slot in the sample entry port
3. Insert the tube and sample processing will begin

NOTE: If all of the patient identification fields are skipped, and no tube is inserted, the instrument will automatically abort the loading procedure for that sample and resume sample processing for tubes already in sample wheel. If a tube has been inserted, the sample will be automatically assigned an ID number and processed.

NOTE: When manually entering ID, first or last name, always touch the (Green Check seen on the right) icon after each entry. If this step is skipped, the information will not print on the results. 

8.5. Format of Automatically Assigned Identification

The format for identification numbers *automatically assigned by the instrument is as follows:*

XX	Two (2) digits to identify <u>position in sample wheel</u>
+	
XX	Two (2) digits to identify <u>session of the day</u>
+	
XXXX	Four (4) digits to identify <u>sample of the day</u>
<hr/>	
XX XX XXXX	Eight (8) digits total

9. Sample Collection

9.1. Compatibility with CBC Collection Tubes

The instrument has been designed to accept most standard 13x75 mm size EDTA blood collection pierceable tubes, including the BD Microtainer® MAP Microtube and Sarstedt S-Monovette® (13x65 mm, 3.4 mL EDTA Tube)



WARNING: Do not use sample if the stopper is missing!

9.2. Collection Procedure (conducted by trained personnel only)⁸

- a) Use standard phlebotomy equipment and personal protection according to your laboratory requirements.
- b) Prepare patient.
- c) Select EDTA, lavender top tube, needle and needle holder.
- d) Open the sterile needle package. Do not remove the needle cap. Screw the needle into the plastic holder and insert the tube into the holder. Do not pierce the tube as this will result in a loss of vacuum pressure.
- e) Position the patient arm for drawing blood. The patient should be comfortably positioned with the sleeve rolled up and the arm extended and supported by the blood drawing chair or bed.
- f) Apply the tourniquet 3 to 4 inches above the puncture site. It should be restrictive enough to be slightly uncomfortable for the patient. Tourniquet should not be on any longer than 1-2 minutes.
- g) Ask the patient to make a loose fist. Any vigorous hand exercise like "pumping" must be avoided because it can affect test results.
- h) Select a good venipuncture site. The larger, fuller median cubital veins are used most frequently.
- i) Clean the puncture site. Use the alcohol wipe and make a smooth circular pass of the puncture site moving in an outward spiral from the zone of penetration. Allow the skin to dry before proceeding. Do not touch the puncture site after cleaning.
- j) Perform the venipuncture holding the needle/tube assembly in your dominant hand, remove the needle cap.
- k) Align the needle/tube assembly with a 15 degree angle to the skin. Use a quick, but small thrust to penetrate the skin and enter the vein in one motion, if possible.
- l) Holding the plastic tube holder's flange with the tube below the puncture site, push the tube onto the needle and puncture the stopper. Keep the tube at an upright angle to prevent tube additives from entering the patient. Blood should flow when the needle punctures the stopper.
- m) Remove the tube when blood flow stops. The tube should be gently inverted 5-8 times immediately after being removed from the patient to mix the specimen. **TO AVOID HEMOLYSIS, DO NOT MIX VIGOROUSLY.**
- n) Remove the needle quickly to minimize pain and immediately apply gauze and a fresh bandage
- o) Dispose of the needle and holder as one unit.
- p) Label tube.

NOTE: Follow your institution's current procedures for capillary blood collection when using the BD Microtainer® MAP Microtube

⁸ from Department of Pathology, Dartmouth-Hitchcock Medical Center, Lab Handbook, Phlebotomy Procedures

10. Calibration

iSED instruments are factory calibrated utilizing samples which are compared with results from a unique Reference Instrument. The Reference Instrument is correlated with the reference Westergren method. The instrument range is from 1 to 130mm/hr. During normal operation, parameters affecting calibration are constantly monitored and, if not within expected limits, a warning is given, and further testing prevented.

11. Limitations of Procedure

Some interferences which increase ESR:

- increased level of fibrinogen, gamma globulins
- technical factor: mechanical vibration, high room temperature

Some interferences which decrease ESR:

- abnormally shaped RBC (sickle cells, spherocytosis)
- technical factors: low room temperature, delay in test performance, clotted blood sample, excess anticoagulant, or bubbles in tube

NOTE: ESR is a nonspecific reaction. It is highly recommended to perform other tests together with ESR, since an ESR value is not enough to exclude that the patient is not affected by a pathology or to diagnose a pathology.

12. Results

12.1. Expected Values

The reference values found in the table below are averages found in males and females. An increase in these values can be a sign of multiple different health issues that should be diagnosed by a physician or qualified individual.

Sedimentation Rate Reference Value (mm/hr) ⁹	
Males under 50 years old	< 15
Males over 50 years old	< 20
Females under 50 years old	< 20
Females over 50 years old	< 30

The ranges provided are for reference only. All laboratories should follow their laboratory's protocol for verifying their own reference ranges.

12.2. Results Format

Results are shown on screen after analysis and also printed by the instrument's internal printer. Data format is as follows:

Date format: Month/Day/Year
Time format: Hour/Minute/Second
Result format: mm/Hour

Example of Normal Results Print Out

=====	
Date: 03/25/2013	Date of analysis
Time: 13:36:24	Time result printed
iSED Sn: 00001	Instrument serial number
ID: 812409	Barcoded sample identification
ESR (mm/h): 15	Format of ESR result reported
=====	

⁹ Keohane, E. M., Otto, C. N. and Walenga, J. M. (2020) Rodak's hematology : clinical principles and applications. Sixth edn. St. Louis, Missouri: Elsevier.

Example of High Results Print Out

```
=====
Date: 03/25/2013           Date of analysis
Time: 13:36:24           Time result printed
iSED Sn: 00001           Instrument serial number
ID: 812409              Barcoded sample identification
ESR (mm/h): 130       Format of print out if high ESR result reported
=====
```



Example of Low Results Print Out

```
=====
Date: 03/25/2013           Date of analysis
Time: 13:36:24           Time result printed
iSED Sn: 00001           Instrument serial number
ID: 812409              Barcoded sample identification
ESR (mm/h): 1         Format of print out if low ESR result reported
=====
```

12.3. Printed Results with Error Message



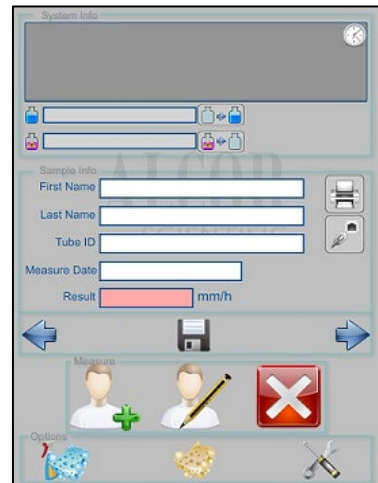

In the event that the instrument is unable to analyze the sample and report results, the print out will replace the 'ESR (mm/h):' field with an error message. **For more information on Error Messages, please reference to Section 16.**

12.4. Reprinting of Results (Entire day)

1. On the home screen touch the  icon to locate the file to be reprinted (note: filename is date of testing)
2. Once the file is located, select the file by touching the file (the field will be highlighted to indicate it was selected)
3. Touch the  icon on the File Screen and all the results for the selected file will reprint



12.5. Review/Printing/Retransmitting a Single Result

From the home screen use the  or  icons to scroll through each result. Once you have located the result press the printer icon  to print or computer connection icon  to retransmit the result to your LIS. This will allow only the printing or retransmission of a single result.

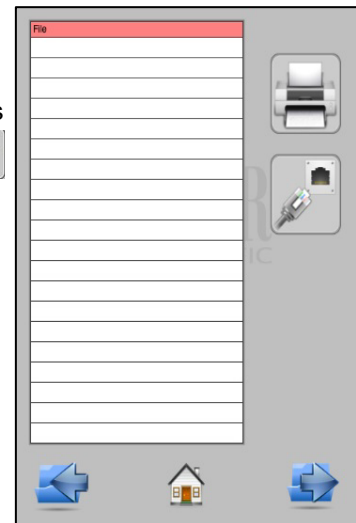

13. Performance

Correlation:

302 samples have been tested on iSED and compared with results obtained from the Westergren method. The comparisons demonstrate equivalence to the Westergren method. See Recommended Correlation Protocol (112-07-002) for detailed instructions.

- Sample result range 0 to 137 mm/hr
- N=302
- Slope=0.98
- Intercept=+1.81
- R=0.98

** These values do not indicate the expected performance of your ISED correlation

Repeatability/Stability:

Samples have been tested in the iSED to determine sample repeatability and post storage measurement stability. See iSED Precision Test Protocol (112-07-004) for detailed instructions.

N=5, sample range 15 to 60 mm/hr.
N=27, sample range 13 to 97 mm/hr.

sample to sample repeatability CV = 6%
24hr @4°C avg CV = 8.1%

** These values do not indicate the expected performance of your ISED Precision and Sample Stability studies

Carry-over:

See iSED Inter-Sample Carry Over Test Protocol (112-07-005) for detailed instructions.

14. Smart Cards

In order to process and analyze samples, tests, known as 'credits', must be downloaded onto the instrument from a smart card preloaded with tests of various quantities.



14.1. Downloading Credits from Test Card

1. With the arrow facing upward and forward, insert the test card into the smart card reader located on the front of the instrument
2. Once inserted, the credits will automatically download onto the instrument and the analyzer will indicate with a message on the screen.
3. Total credits available will include the newly downloaded credits and any residual credits prior to download
4. Once all credits have been downloaded onto the instrument, the test card can be removed and discarded



NOTE: If instrument has negative credits and additional credits have been downloaded from the smart card, the total credits available will be reduced by the total negative credits.

14.2. Low and Zero Credit Indicators and Alarms

In the case of 'low' or 'zero' credits, a message will appear on the screen and be accompanied by an alarm alerting the operator of an error or warning message.

Zero Credits

In the event there are no test credits remaining the below error message will appear on the screen and can be resolved by loading test credits.



Abort Request: If this option is selected, the instrument automatically aborts the sample loading procedure

For instructions on downloading credits from the test card, please refer to Section 14.1.

Low Credits

In the event the credits are below the alarm threshold; a warning message will appear on the screen to remind the operator to order or load additional credits.

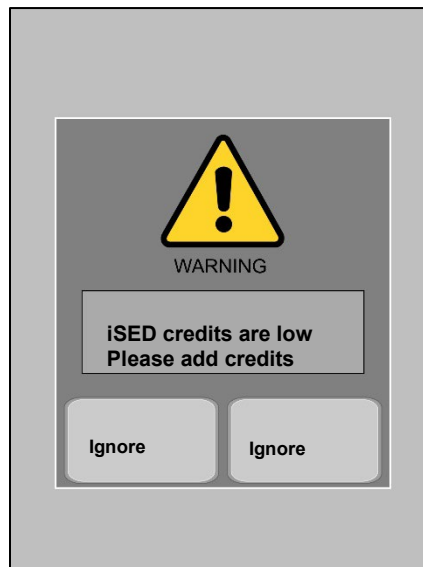

Ignore Request: If this option is selected, the instrument skips the warning and the operator can continue the sample loading process as described in **Section 8.2**.

For instructions on downloading credits from the test card, please refer to Section 14.1.

15. Routine Maintenance

15.1. Replacing Printer Paper

A green LED light on the printer will flash to indicate it is out of paper. To replace the printer paper in the instrument, the procedure below should be followed:

1. Pull the lever (A) until the lid is released from its locked position.
2. Open the paper cup lid and remove the remaining paper
3. Insert thermal paper roll into the printer with the paper unwinding from the bottom of the roll
4. Reel off a few inches from a new roll of paper. Hold approximately two (2) inches of paper outside the printer as you place the new roll into the reservoir
5. Close the lid by applying equal amounts of pressure on each side ensuring the lid is in the locked position

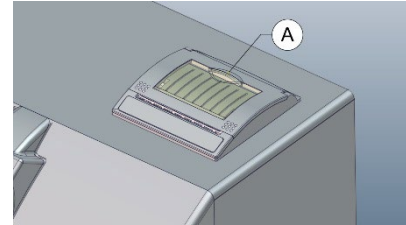

15.2. Replacing/Emptying the Waste Bottle



WARNING: Wear Personal Protective Equipment (PPE) such as protective gloves and safety glasses during this operation.

NOTE: A washing cycle should be run prior to replacing the waste bottle.

1. Open the front door to access the bottle compartment (A)
2. Locate the waste bottle in the upper compartment (B)
3. Disconnect the LUER connector (C) from the waste bottle screw cap
4. Remove the waste bottle from the instrument and dispose according to your laboratory biologic waste protocol
5. Replace the waste bottle in the upper compartment (B) and **firmly** reconnect the LUER connector (C) on the plastic screw cap with the vent hole positioned at top
6. Close the front door (A)
7. Press waste bottle emptied icon on Home Screen.

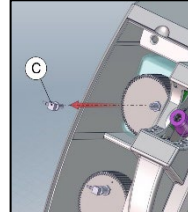
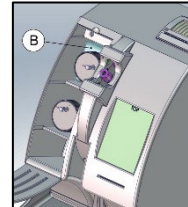
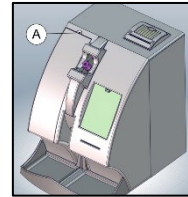

iSED software ver. 3.01A or later only

NOTE: Be sure to replace the plastic cap with the vent hole at the top.

NOTE: Be careful not to kink the line when replacing the bottle.

NOTE: It is recommended that the waste bottle be emptied daily.

NOTE: This procedure can be done without the waste alarm being triggered

15.3. Waste Bottle Full Indicators and Alarms

In the case of a full or nearly full waste bottle, a warning message will appear on the screen and be accompanied by an alarm alerting the operator of an error or warning message.



WARNING: This action should be done when this message appears.

Full Waste Bottle

In the event the waste bottle is full the below error message will appear on the screen and can be resolved by choosing one of the two options indicated.



Abort Request: If this option is selected, the instrument automatically aborts the sample loading procedure

Bottle Replaced: This option must be selected immediately after the operator replaces the waste bottle. The waste bottle counter will automatically reset once this button has been pressed and the instrument will continue with the sample loading or washing processes. **For instructions on replacing the waste bottle, please refer to Section 15.2.**

Nearly Full Waste Bottle

In the event the waste bottle is nearly full the below warning message will appear on the screen and can be resolved by choosing one of the two options indicated.



Ignore Request: If this option is selected, the instrument skips the warning and the operator can continue the sample loading process as described in **Section 8.2**.

Bottle Replaced: This option must be selected immediately after the operator replaces the waste bottle. The waste bottle counter will automatically reset once this button has been pressed and the instrument will continue with the sample loading or washing processes. **For instructions on replacing the waste bottle, please refer to Section 15.2.**



WARNING: Wear Personal Protective Equipment (PPE) such as protective gloves and safety glasses during this operation.

15.4. Replacing iWASH Bottle

1. Open the front door to access the bottle compartment (A)
2. The iWASH bottle is located in the lower compartment (D)
3. Disconnect the LUER connector (E) from the iWASH bottle screw cap
4. Remove the empty iWASH bottle, unscrew the cap and replace it with a new iWASH bottle
5. Place the new iWASH bottle in the lower compartment and **firmly** reconnect the LUER connector (E) on the plastic screw cap with the vent hole positioned at top
6. Close the front door (A)
7. Press iwash changed icon on main page.

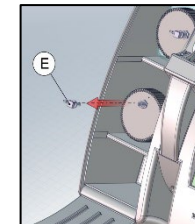
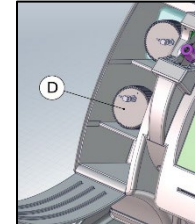
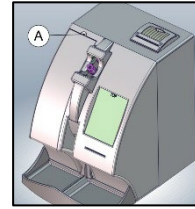

iSED software ver. 3.01A or later

NOTE: Be sure to replace the plastic cap with the vent hole at the top.

NOTE: Be careful not to kink the line when replacing the bottle.

NOTE: The instrument is programmed to perform self-cleaning after being idle for fifteen (15) minutes following the last sample tested. The process takes approximately one (1) minute and utilizes 4.5mL of iWASH for each iWASH cycle. Once completed, testing can resume as normal.

NOTE: This procedure can be done without the wash alarm being triggered.

15.5. iWASH Bottle Empty Indicators and Alarms

When the iWASH bottle is empty or nearly empty, a message will appear on the screen and be accompanied by an alarm alerting the operator of the error or warning message.



WARNING: This action should be done when this message appears.

Empty iWASH Bottle

In the event the iWASH bottle is empty the below error message will appear on the screen and can be resolved by choosing one of the two options indicated.



Abort Request: If this option is selected, the instrument automatically aborts the sample loading procedure

Bottle Replaced: This option must be selected immediately after the operator replaces the iWASH bottle. The instrument will not allow the operator to delay iWASH bottle replacement if this option is selected. The iWASH bottle counter will automatically reset once the iWASH Bottle Replaced button has been pressed and the instrument will continue with the sample loading or Washing processes. **For instructions on replacing the iWASH bottle, please refer to Section 15.4.**

Nearly Empty iWASH Bottle

In the event the iWASH bottle is nearly empty the below warning message will appear on the screen and can be resolved by choosing one of the two options indicated.



Ignore Request: If this option is selected, the instrument skips the warning and the operator can continue the sample loading process as described in **Section 8.2**.

Bottle Replaced: This option must be selected immediately after the operator replaces the iWASH bottle. The instrument will not allow the operator to delay iWASH bottle replacement if this option is selected. The iWASH bottle counter will automatically reset once the iWASH Bottle Replaced button has been pressed and the instrument will continue with the sample loading or washing processes. **For instructions on replacing the iWASH bottle, please refer to Section 15.4.**

15.6. Replacing the Fuse



CAUTION: Unplug the instrument from the wall outlet before replacing the fuse.



CAUTION: For continued protection against risk of fire and hazard, replace only with the same type and rating fuse.

Requirements for this procedure:

3/16 blade Screwdriver (1)

Fuse T2A 250V 5x20mm  (1)

1. Remove the fuse cover located on the rear of the instrument by turning it counterclockwise

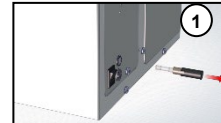

2. Remove the fuse holder from the instrument

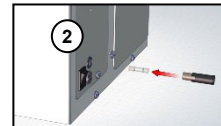

3. Remove the old fuse from the fuse holder

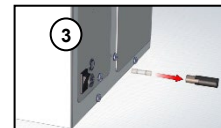

4. Insert the new fuse of the same type and rating into the fuse holder

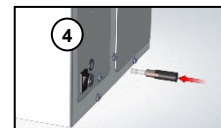

5. Return the fuse holder into the instrument and lock it back into place by turning it clockwise



16. System Status, Error Codes and Warning Messages

The instrument touchscreen display has a gray highlighted “window” at the top of the screen where all active system messages appear. There is a 4-line display, with the first two lines dedicated to System Status Messages reporting on the number of available sample wheel positions and the number of Test Credits remaining. An animated emoticon in the lower right corner of the status window provides a quick visual reference to general operating status.

16.1. System Status Messages

Each of these messages display on the touch screen as the system is processing specimens.

Line 1 & 2	Status
“Available Credit” (2 nd Line)	‘Quantity’ Tests Available Low – Purchase More Tests (Alarm) 0 – No Tests Available
Lines 3 & 4	Status
“iSED Is”:	
Positioning Sampler	Sample Wheel being positioned for loading a new tube, aspiration or tube extraction
Waiting Cuvette	Waiting for Sample (repeating beeps)
Memo Sample	Sample Barcode Successfully Read, or barcode acquisition time window elapsed
Mixing	Sample wheel rotating to mix all samples.
Withdrawing	Sample wheel positioned and probe is withdrawing sample
Measuring	Sample is positioned in read cell and analysis is underway
Extracting	Testing is complete and tube is being extracted from iSED instrument
Idle	All scheduled testing complete

NOTE: Unless the third line starts with “iSED is Warning” or “iSED is in Error”, the operation is normal. Descriptions for iSED Warning and Error messages are listed in the following sections.

16.2. System Warning Messages

Warning Messages are general messages about the instrument's current operation. The following alert will appear on the instrument's screen and be accompanied by the appropriate warning message:



The table below shows examples of the warning messages you may see while operating the instrument and some possible solutions. Should you experience other warning messages, please refer to the Troubleshooting Chart found in this manual.

"iSED is in Warning"	Solution
Available Positions = 0	Please wait for next available slot
'Unavailable credit Please Add credits'	Download more credits to continue; see section 14.1
'iSED Credits are low Please add credits'	Download more credits or skip to continue; see section 14.1
'Waste Bottle Full' message displayed and Alarm	Remove and replace waste bottle; see section 15.2
'Wash Bottle Empty Message' displayed and Alarm	Replace iWASH bottle; see section 15.4
Ejection Out	Check for blocked ejection port
Paper Error/Out (Flashing Green Light)	Replace paper; see section 15.1
Rotor Finger	Remove any foreign object from area around sample entry port
Wash not Ok 'Wash Nok' displayed	Check to see that iWASH bottle line is connected and there are no kinks in the line. Run wash cycle again.

16.3. System Error Messages

In the event of a system error, the following alert will appear on the instrument's screen and be accompanied by the appropriate error message:

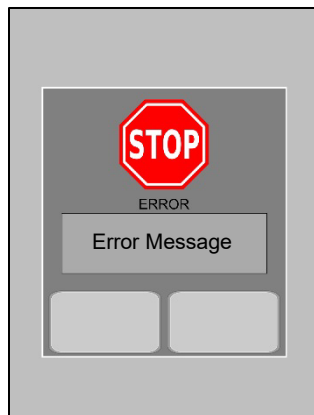

The table below shows examples of the error messages you may see while operating the instrument and some possible solutions. Contact Technical Support if the error cannot be resolved by any solution provided below:

"iSED in Error"	Solution
Rotor Home	Restart the unit, eject the sample and re-enter the sample. If the error appears again, contact Technical Support.
Syringe Home	Restart the unit, eject the sample and re-enter the sample. If the error appears again, contact Technical Support.
Syringe Up	Restart the unit, eject the sample and re-enter the sample. If the error appears again, contact Technical Support.
Syringe Probe	Restart the unit, eject the sample and re-enter the sample. If the error appears again, contact Technical Support.
Syringe No Tube	Restart the unit, eject the sample and re-enter the sample. If the error appears again, contact Technical Support.
Ejection home	Restart the unit, eject the sample and re-enter the sample. If the error appears again, contact Technical Support.
Ejection lock	Restart the unit, eject the sample and re-enter the sample. If the error appears again, contact Technical Support.
Ejection Out	Restart the unit, eject the sample and re-enter the sample. If the error appears again, contact Technical Support.
Ejection Tubes Jam	Remove source of jam. Sensor will reset once tube is removed. If problem persists contact Technical Support
Tail sensor	Restart the unit, eject the sample and re-enter the sample. If the error appears again, contact Technical Support.
Unable to withdraw	Check sample volume and perform wash cycle. If the error message appears again, contact Technical Support.

16.4. Sampling Error Messages

In the event of a sampling error, the following messages will be printed:

Error Message (Printed)	Explanation/Solution
"No Flow Detected"	This error appears when the system is able to withdraw the correct volume from the sample tube but is not able to detect the sample moving in the reading position Contact Technical Support
"Abnormal Sample"	Human blood, when stopped into the reading cell, must present a drop in light transmission. This error indicates the detection of an anomalous sample. New specimen should be drawn
"Abnormal Reaction"	Usually a hematological sample, after being positioned into the reading cell, starts to form rouleaux (aggregates) with the increase of the detected signal. If the signal detected decreases instead, the error code is provided, indicating a non-standard condition.
"Insufficient Data Points"	This error appears when the reaction takes too much time to develop, or when the drop of the signal of error 3 takes too much time to end. This is an indication of hyper-viscosity of the sample, or hydraulic malfunctioning. New specimen should be drawn
"Sample Too Dark"	Indicates a very high HCT of the sample, with a consequential unreliable result. Instead of providing an inaccurate result, the system provides the error message. New specimen should be drawn
"No HCT Detected"	Indicates a very low HCT of the sample, with a consequential unreliable result. Instead of providing an inaccurate result, the system provides the error message. New specimen should be drawn
"Sample Too Clear"	Indicates a very low HCT of the sample, with a consequential unreliable result. Instead of providing an inaccurate result, the system provides the error message. New specimen should be drawn
"Unable to Withdraw"	This error appears when the system is not able to aspirate the correct volume from the sample tube Contact Technical Support

16.5. Print Out of Sampling Error Message

In the event of a sampling error, the instrument will try to resolve it automatically up to a maximum of three (3) attempts. If after the third attempt, the instrument is unable to resolve the sampling error, an error message will be printed as follows:

```
=====
Date: 03/25/2013           Date of analysis
Time: 13:36:24            Time result printed
iSED Sn. 00001            Instrument serial number
ID: 812409                Barcoded sample identification
Error: Abnormal Reaction
=====
```

Please contact Technical Support should your instrument display and/or print a sampling error message.

17. Troubleshooting

iSED is a fast and reliable medical instrument, however, as with any instrument, problems may occur. The following Troubleshooting Chart will help diagnose some simple problems and offer a solution.

Situation	Possible Causes	Solutions
Instrument will not power ON	Loose power connections Bad fuse	Check all power connections at the rear of instrument, power supply, and wall outlet. Reconnect power cord at all locations. Wait 30 seconds. Plug back in. Remove fuse cap immediately above power connection on rear of instrument. Check fuse and replace if necessary. See Section 15.6.
Sample tube stuck in the wheel	Tube dropped during sample entry	Power OFF the instrument and manually remove the tube(s) from the wheel.
Touch screen not responding	Touch screen is out of calibration	Contact Technical Support for calibration instruction.
Results are running low/high	Lipemic, hemolyzed, or clotted specimen Pre-analytical sample handling change or system error	Verify condition of specimen. Run controls. Once complete if results are within range, resume normal operation; if out of range, discontinue testing and contact Technical Support.
Instrument is not scanning patient barcode	Damaged, incompatible, or no barcode label Barcode reader misaligned	Validate barcode label Contact Technical Support for instruction.

For troubleshooting issues not covered in this manual, please contact Technical Support or an authorized ALCOR Distributor.

18. Safety Precautions

18.1. General Considerations



WARNING: It is recommended that blood samples be handled wearing gloves and that all other appropriate precautions be taken when dealing with potentially infectious biological material.



CAUTION: The instrument should be disconnected from power supply before performing any cleaning, maintenance, or exposing internal electrical components and circuits.

NOTE: If used in a manner not specified by the manufacturer, damage or injury could result.

18.2. Biological Waste

Biological hazards can be found in all human and animal body fluids and/or tissues.

While using the instrument, it is suggested that your laboratory's Good Laboratory Practices are followed. Please refer to, and follow, all local regulations, department safety guidelines, and bio-safety policies for disposal of bio-hazardous waste.



WARNING: Dispose blood tubes into a biohazard container.



WARNING: Dispose sharps into a biohazard sharps container.



WARNING: All other bio hazardous waste should be deposited into a biohazard bag.



WARNING: Biohazard bags will be placed into a Medical Waste Management bin for pick up.



WARNING: Dispose liquid waste container contents in a manner consistent with local regulations and laboratory procedures.



WARNING: Empty Sample Collection Tray when full to avoid a potential biohazard spill due to broken samples.

19. Preventative Maintenance

It is recommended that the instrument be kept free from dusty and particulate environments at all times for best performance. If such environments are unavoidable, periodically inspect interior surfaces and rear fan assembly for heavy dust accumulation and clean as needed.

19.1. Deep Clean Procedure

The analyzer will prompt the user when the Deep Clean is needed. The frequency for Deep Cleaning is monthly or every 1000 samples run, whichever comes first. This procedure will clean the aspiration pathway from the needle to the reading cell.

Materials needed:

1. Empty and unused 13x75 tube (Do not use SST tube)
2. 6-7 % hypochlorite (Bleach) Do not dilute unless, greater than 7%.
3. On board iWASH solution

Procedure:

1. Add approximately 3.5 ml of 6-7 % hypochlorite to unused 13 x 75 tube.
2. Once screen prompts you, insert the Deep Clean tube into the sample loading position and press continue. (Pressing abort will stop the deep clean process)
3. The analyzer will run 2 wash cycles, then automatically perform the Deep Clean (3 minutes), and conclude by automatically running two additional wash cycles.
4. Once the deep clean procedure is completed remove and discard the bleach filled tube.

Note: This procedure can also be activated by pressing the Deep Clean  icon on the home page. (iSED software V3.01A or later only)

19.2. Pump Tubing Change Required Message

iSED systems with software version 3.03A or later: After 200 hours of continuous pump use, the iSED will alarm and generate a message that a 'Tubing Change is Required'. This message only serves as a warning that maintenance should be performed and does not prevent the analyzer from operational use.

iSED systems with software version 3.02 or earlier: The user will not be prompted to change the tubing. The tubing replacement should be done after 30,000 aspirations.

Technical Support should be contacted by phone at (800)495-5270 or +1 (401) 737-3774. Once you have contacted Technical Support, parts and instructions for items that should be replaced will be sent.

19.3. 30,000 Test Aspirations Message

After 30,000 aspirations the iSED will alarm and generate a message to contact Technical Support. Please contact Technical Support @ (800)495-5270 or +1 (401) 737-3774 when this occurs. Once you have contacted Technical Support, parts and instructions for items that should be replaced will be sent.

This message only serves as a warning that maintenance should be performed and does not prevent the analyzer from operational use.

19.4. General Considerations

- Do not use sterilizing solutions
- Prolonged exposure to alcohol or strong cleaners may damage the instrument housing
- Only use water and mild detergents to wipe the surface of the instrument sample tray



CAUTION: Always disconnect the instrument from the AC outlet prior to changing fuse.

19.5. Spare Parts

Spare parts can be purchased by calling ALCOR Customer Service Department or your local authorized ALCOR distributor. Please contact our Technical Support Department.

Parts deemed necessary by Technical Support will be supplied at no charge for customer that are under warranty or has an active service contract.

20. Technical Support

If you experience any problems while operating the instrument, please contact ALCOR Scientific, or your local authorized ALCOR Scientific Distributor. ALCOR Scientific offers Technical Support Monday through Friday 8:30am-5:00pm EST (excluding all USA Federal Holidays). They can be reached by any of the following:

Toll Free: (800) 495.5270 (USA Only) **Fax:** +1 (401) 737.4519

International: +1 (401) 737.3774

Mail: ALCOR Scientific
20 Thurber Blvd
Smithfield, RI 02917
USA

Email: techservice@alcorscientific.com



WARNING: In the event that the instrument must be returned for service, EMPTY ALL FLUID CONTAINERS BEFORE SHIPPING.



CAUTION: Remove any liquid waste or on-board sample tubes and decontaminate before returning for service.

Any instrument containing accumulated blood must be cleaned prior to shipment to the manufacturer. This decontamination is required by Federal Law (Title 48 and 49 of the Federal Regulations) in accordance with the Environmental Protection Agency's Regulations for Biohazard Waste Management.

21. Technical Specifications

Name of Device	<i>iSED</i> [®]
Type of Device	Automated analyzer for the determination of erythrocyte sedimentation rate of human whole blood
Principle of Measure	Photometric Rheoscope
Sample Requirements	100µL whole blood (500µL dead volume)
Analytical Range	1-130mm/hr
Results	Printed; first result available 20 seconds from programmed mixing time.
Serial Port	Serial RS232 DB9 port for LIS connection
Barcode	Internal
Printer	Internal
Operating Environment	10° - 30° C
Storage/Transport Environment	-20° - 65° C
Humidity	15% - 85% (non-condensing)
Power Supply	100-240 VAC
Power Consumption	160W
Frequency	50-60 Hz
Dimensions (L x W x H)	36 x 27 x 34 cm 13 x 11 x 14 in
Weight	13.6 kgs 30 lbs
Operational Altitude	3000 Meters
Storage Altitude	3000 Meters
Restrictions	For Professional Use Only
** Rating of 2000 meters for device serial number 02870 and earlier.	

22. Quick Reference

For your convenience, a separate Reference Card was included with your new instrument. Should you misplace the Reference Card a summary the information has also been included in the Operator's Manual and found below:

iSED[®] QUICK REFERENCE CARD

Sample Requirement

100µL whole blood
(500µL dead volume)

1µL = 1 microliter

Tube Requirement

Standard EDTA anti-coagulant
(13 x 75mm) test tube, with piercable cap





Sedimentation Rate Reference Values (mm/hr)*

Males under 50 years old	< 15
Males over 50 years old	< 20
Females under 50 years old	< 20
Females over 50 years old	< 30

**The ranges provided are for reference only. All laboratories should establish their own reference ranges based on the patient population served.*

Reference: Keohane, E. M., O'ffo, C. N. and Walenga, J. M. (2020) Rodak's hematology : clinical principles and applications. 10th edn. St. Louis, Missouri: Elsevier

Operating Procedure

1. Touch 'Add Sample' icon 
2. The sample wheel will rotate to position the next open slot in the sample entry port.
3. Insert the barcoded tube, making sure the barcode is oriented to the right. A red light will illuminate and a distinctive beep will sound confirming that the barcode has been successfully recognized.
 **Load tightly capped tubes only.**
4. Repeat this sequence until all samples have been entered and/or all positions in the sample wheel are occupied.
5. Sample processing will begin automatically once all tubes have been entered and mixing is complete.

Please refer to the ISED Operator Manual for the complete operating procedure.

For Technical Support contact:
401.737.3774 or techservice@alcorscientific.com



ALCORSCIENTIFIC.COM

23. Warranty Information

Manufacturer's Warranty

ALCOR Scientific warrants that this product is free from defects in materials and workmanship for a period of One (1) Year from the date of original purchase (except as noted below). During the stated one (1) year period, ALCOR Scientific shall, at its sole discretion, repair or replace at no charge to the original end use purchaser or person receiving the product, any product found to be defective due to material or workmanship. In the case of replacement, a new or reconditioned product may be provided at ALCOR's option.

This warranty is limited to the repair or replacement due to defects in parts or workmanship and shall not include any maintenance and repairs or replacement of parts due to normal wear and tear. Parts required which were not defective shall be replaced at additional costs, and ALCOR Scientific shall not be required to make any repairs or replace any parts which are necessitated by abuse, accident, alteration, misuse, neglect, maintenance by other than ALCOR Scientific, an authorized ALCOR service agent, or failure to operate the instrument in accordance with instructions. Further, ALCOR Scientific extends no warranty for malfunction or damage to its products resulting from improper or unreasonable use or maintenance; failure to follow operating instructions; connections to improper voltage supply; unauthorized alteration or modification of original condition; damages caused by inadequate packing or shipping procedures; loss of, damage to or corruption of stored data; and any damage due to use of operating supplies other than those manufactured or recommended by ALCOR Scientific.

ALCOR Scientific reserves the right to make changes in design or software of this instrument without obligation to incorporate such changes into previously manufactured instruments.

Disclaimer of Warranties

THIS WARRANTY IS EXPRESSLY MADE IN LIEU OF ANY AND ALL OTHER WARRANTIES EXPRESS OR IMPLIED INCLUDING THE WARRANTIES OF MERCHANTABILITY AND FITNESS FOR USE.

This warranty is void if the label bearing the serial number has been removed or defaced.

Limitations of Liability

In no event shall ALCOR Scientific be liable for indirect, special or consequential damages, even if ALCOR Scientific has been advised of the possibility of such damages. Any transport costs and risks are not covered by this warranty. In the event that the instrument shall be returned to ALCOR Scientific for servicing, replacement or for other reasons, it must be shipped and received in original packaging. Otherwise, additional charges may be incurred. Proof of purchase from an authorized ALCOR distributor and proof of delivery may be required.

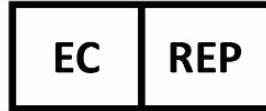

EMERGO EUROPE
Prinsessegracht 20
2514 AP, The Hague
The Netherlands
(+31) 70 345 8570

Australian Sponsor

Emergo Australia
Level 20 Tower II
Darling Park
201 Sussex Street
Sydney, NSW 2000
Australia

www.alcorscientific.com

© Copyright 2022, ALCOR Scientific

ALCOR, iSED, iWASH, iWASTE, and Seditrol are
registered trademarks of ALCOR Scientific



ALCOR Scientific
20 Thurber Boulevard
Smithfield, RI 02917 USA
(T) + 1 401 737-3774
WWW.ALCORSCIENTIFIC.COM